



Plano de Contas Nacional



Oficinas/Painéis



GRUPO/AREA	Código	Nome	Sigla Oficina	CH
PLANEJAMENTO E ORÇAMENTO	1	Plano Plurianual (PPA)		4
	2	Lei de Diretrizes Orçamentárias (LDO)		8
	3	Lei Orçamentária Anual (LOA)		4
CONTRATAÇÕES PÚBLICAS LEGISLAÇÃO/FUNDAMENTOS	10	Lei de Licitações		8
	11	Alterações à Lei de Licitações - Projeto de Lei N.º 7709/2007		4
	12	Pregão – Legislação		4
	13	Contratos Administrativos		4
	14	Implementação do Capítulo V do Estatuto Nacional da Microempresa e da Empresa de Pequeno Porte		4
	15	Convênios e Legislação		4
	20	Nocões de Contabilidade		4
	21	Plano de Contas Nacional		4
	22	Manual da Receita Nacional		4
	23	Manual da Despesa Nacional		4
CONTABILIDADE APLICADA AO SETOR PÚBLICO	24	Manual das PPP		4
	25	Elaboração das Demonstrações Contábeis		4
	26	FUNDEB – Legislação e Procedimentos Contábeis		4
	27	Contabilidade Aplicada aos Regimes Próprios de Previdência Social		4
	28	Lançamentos Contábeis Típicos da Administração Pública		4
	29	Normas Brasileiras de Contabilidade Aplicadas ao Setor Público		4
	30	Fundamentos da Lei de Responsabilidade Fiscal		4
LEI DE RESPONSABILIDADE FISCAL	31	Programação Financeira e Cronograma Mensal de Desembolso		4
	32	Regras das Despesas Públicas após a LRF		4
	33	Despesa com Pessoal e seus Limites		4
	34	Dívida pública e Operações de Crédito		4
	35	Restrições Institucionais e Sanções Pessoais relacionadas à LRF		4
TRANSPARÊNCIA DA GESTÃO PÚBLICA	40	Transparência na Gestão Fiscal		4
	41	Sistema de Informações sobre Orçamento Público em Educação (SIOPE) e Elaboração do Demonstrativo da Educação (Anexo X do RREO)		4
	42	Sistema de Informações sobre Orçamento Público em Saúde (SIOPS) e Elaboração do Demonstrativo da Saúde (Anexo XVI do RREO)		4
	43	Sistema de Informações do Tesouro Nacional (SISTN)		4
CONTROLE GOVERNAMENTAL	44	Ferramentas de Gestão para o Setor Público		4
	50	Controle Externo		4
	51	Controle Interno		8





Oficina 21 - Plano de Contas Nacional

Duração: 04 h

Conteúdo: 1. Introdução. 2. Técnica de elaboração de plano de contas. 3. Exemplificação com o Plano de Contas Nacional. 4. Estrutura do Plano de Contas Nacional 5. Função das Classes e Grupos. 6. Sistemas de Contas.

Desenvolvimento: Aula expositiva sobre os principais aspectos a serem verificados no momento da elaboração de um plano de contas, utilizando como modelo exemplificativo o utilizado pela administração pública federal. Demonstração das vantagens de se possuir indicadores contábeis relacionados às contas e eventos. Apresentação do que são os eventos de um sistema contábil informatizado, utilizando como parâmetro a tabela de eventos do SIAFI.



Contabilidade Aplicada ao Setor Público

Conceitos e Objetivos

É o ramo da Contabilidade que coleta, registra e controla os atos e fatos da Administração Pública, com enfoque para o patrimônio e suas variações, bem como acompanha e demonstra a execução do orçamento.





Base Legal

A Contabilidade Pública encontra-se embasada na Lei 4.320/64, na LRF e nas NBC, e tem como função:

- ✓ Registrar a previsão da receita e a fixação da despesa relativas ao Orçamento Aprovado para o exercício;
- ✓ Escriturar a execução orçamentária da receita e da despesa;
- ✓ Confrontar a previsão das receitas com a realização das despesas;
- ✓ Controlar as operações de crédito, a dívida ativa, os créditos e as obrigações;
- ✓ Revelar as variações patrimoniais e mostrar o valor do patrimônio.



Tipos de Atos Praticados

De Natureza Orçamentária

- Previsão da Receita
- Fixação da Despesa
- Movimentação de Créditos
- Empenho da Despesa

Administrativos Potenciais

- Convênios
- Avais
- Fiança
- Comodato de Bens
- Acordos, Ajustes





Contabilidade Pública - OBJETO

Patrimônio Público

São aqueles bens que atendem à característica de uso restrito, específico e não generalizado, de propriedade das entidades públicas.



OBJETIVOS

É o de fornecer informações atualizadas e exatas à Administração para subsidiar as tomadas de decisões, aos órgãos de Controle Interno e Externo para o cumprimento da legislação e às instituições governamentais e particulares para fins estatísticos ou de interesse dessa instituição.





CONTA:

Título representativo da formação, composição, variação e situação de um patrimônio, bem como dos atos potenciais praticados pelo administrador que exigem um controle específico.





Plano de Contas:

- É o conjunto de títulos previamente definidos, organizados e codificados com o objetivo de uniformizar o registro contábil dos atos e fatos administrativos.
- É a estruturação ordenada e sistematizada das contas utilizáveis numa entidade.



Condições a serem observadas num Plano de Contas:

- Deve atender às necessidades específicas de cada entidade e suas segmentações de responsabilidade às necessidades de informação de todos os usuários.
- O ponto de partida são as informações contábeis e gerenciais requeridas pelos usuários, sendo papel do contador o monitoramento, aconselhamento e gerenciamento do plano de contas.





Condições a serem observadas num Plano de Contas:

- Os agrupamentos devem ser feitos pensando nos relatórios ou telas que deles se organizarão;
- Os títulos das contas devem refletir imediatamente os elementos patrimoniais que representam – devem ser claros e sucintos;
- Deve ter flexibilidade (margem para ampliação) e operacionalidade.



Condições a serem observadas num Plano de Contas:

- Partindo das informações requeridas pelos usuários, observar a ordem hierárquica;
- A classificação deve partir do geral para o particular;
- As contas devem ser codificadas, ou conterem elementos claros para rápida identificação e assimilação do que representam.





Desdobramentos:

- 1º Nível: Classe;
- 2º Nível: Grupo;
- 3º Nível: Subgrupo;
- 4º Nível: Elemento;
- 5º Nível: Sub-elemento;
- 6º Nível: Item;
- 7º Nível: Sub-item;
- Conta Corrente



Desdobramentos:

- | | | |
|--------------------------|---|--------------------|
| • 1º Nível: Classe; | → | • 1º dígito; |
| • 2º Nível: Grupo; | → | • 2º dígito; |
| • 3º Nível: Subgrupo; | → | • 3º dígito; |
| • 4º Nível: Elemento; | → | • 4º dígito; |
| • 5º Nível: Subelemento; | → | • 5º dígito; |
| • 6º Nível: Item; | → | • 6º e 7º dígitos; |
| • 7º Nível: Subitem; | → | • 8º e 9º dígitos; |
| • Conta Corrente | → | • Código Variável. |





Classe: (Nível de Agregação Máxima)

1 - ATIVO	2 - PASSIVO
3 - DESPESA	4 - RECEITA
5 - VARIAÇÃO PATRIMONIAL PASSIVA	6 - VARIAÇÃO PATRIMONIAL ATIVA



Grupo:

1 - ATIVO 1.1 - CIRCULANTE 1.2 - REALIZ. LONGO PRAZO 1.4 - PERMANENTE 1.9 - COMPENSADO	2 - PASSIVO 2.1 - CIRCULANTE 2.2 - EXIGÍVEL A LONGO PRAZO 2.3 - RES.DE EXERC.FUTUROS 2.4 - PATRIMÔNIO LÍQUIDO 2.9 - COMPENSADO
3 - DESPESA 3.3 - DESPESAS CORRENTES 3.4 - DESPESAS DE CAPITAL	4 - RECEITA 4.1 - RECEITAS CORRENTES 4.2 - RECEITAS DE CAPITAL
5 - VARIAÇÃO PATRIMONIAL PASSIVA 5.1 - RESULTADO ORÇAMENTÁRIO 5.2 - RES. EXTRA-ORÇAMENTÁRIO 5.6 - DESPESAS E CUSTOS	6 - VARIAÇÃO PATRIMONIAL ATIVA 6.1 - RESULTADO ORÇAMENTÁRIO 6.2 - RES. EXTRA-ORÇAMENTÁRIO 6.3 - RESULTADO APURADO





Subgrupo:

1 - ATIVO 1.1 - CIRCULANTE 1.1.1 - DISPONÍVEL	2 - PASSIVO 2.1 - CIRCULANTE 2.1.1 - DEPÓSITOS
3 - DESPESA 3.3 - DESPESAS CORRENTES 3.3.1 - PESSOAL	4 - RECEITA 4.1 - RECEITAS CORRENTES 4.1.1 - INVESTIMENTOS
5 - VAR. PATRIMONIAL PASSIVA 5.1 - RESULTADO ORÇAMENTÁRIO 5.1.3 - MUTAÇÕES PASSIVAS	6 - VAR. PATRIMONIAL ATIVA 6.1 - RESULTADO ORÇAMENTÁRIO 6.1.3 - MUTAÇÕES ATIVAS



Relação das Contas:

- São todas as contas inseridas na estrutura do plano de contas e desdobradas até o nível necessário.



 Semana de Administração Orçamentária, Financeira e de Contratações Públicas Oficina: 21 – Plano de Contas Nacional	
1.0.0.0.00.00 – ATIVO	1º Nível – Classe
1.1.0.0.00.00 – CIRCULANTE	2º Nível – Grupo
1.1.1.0.00.00 - DISPONÍVEL	3º Nível – Subgrupo
1.1.1.1.00.00 – DISPONÍVEL EM MOEDA NACIONAL	4º Nível –Elemento
1.1.1.1.2.00.00 – BANCOS CONTA MOVIMENTO	5º Nível – Subelemento
1.1.1.1.2.01.00 – CONTA ÚNICA DO TESOUREIRO NACIONAL	6º Nível – Item
1.1.1.1.2.01.01 – BANCO CENTRAL DO BRASIL	7º Nível – Subitem



 Semana de Administração Orçamentária, Financeira e de Contratações Públicas Oficina: 21 – Plano de Contas Nacional	
<p>• Contas Escrituráveis ou Analíticas: Admitem registro; Admitem conta-corrente.</p> <p>• Contas Não Escrituráveis ou sintéticas: Não admitem registro; Não admitem conta-corrente.</p>	





ESTRUTURA DA CONTA

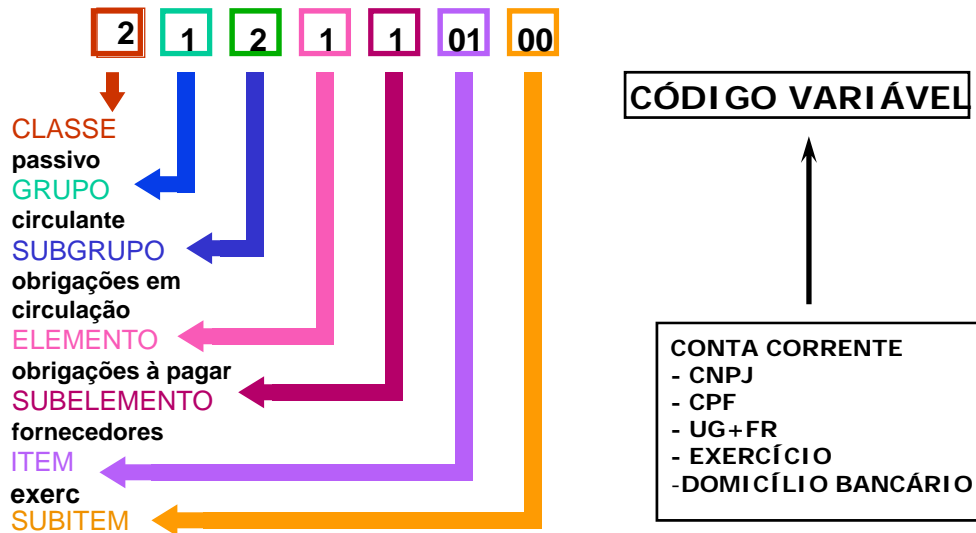

Elemento + Subelemento:

- 3.3.3.9.0.

→ APLICAÇÕES DIRETAS

Item:

- 3.3.3.9.0.30

→ MATERIAL DE CONSUMO





Subitem:

- **3.3.3.9.0.30.05**



Portaria Interministerial STN/SOF nº 163/2001:
Nível Optativo para os entes.

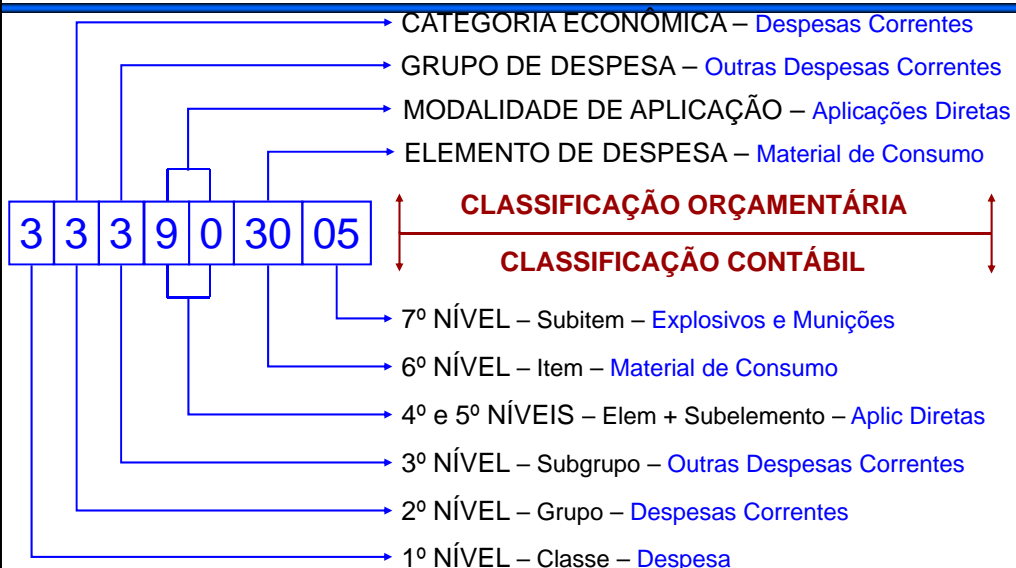



DESPESA

3.X.X.XX.XX.YY

CLASSE
CATEGORIA ECONÔMICA
GRUPO DE DESPESAS
MODALIDADE DE
APLICAÇÃO
ELEMENTO DE DESPESA
SUBITEM



RECEITA

4.Y.Y.Y.Y.YY.YY

CLASSE
CATEGORIA ECONÔMICA
SUBCATEGORIA
ECONÔMICA
FONTE
RUBRICA
ALÍNEA
SUBALÍNEA





SISTEMA DE CONTAS

SISTEMA FINANCEIRO

SISTEMA PATRIMONIAL

SISTEMA ORÇAMENTÁRIO

SISTEMA DE COMPENSAÇÃO



SISTEMA FINANCEIRO

Relaciona-se com os ingressos (entradas) e os dispêndios (saídas) de recursos, isto é, com o registro dos recebimentos e pagamentos de natureza orçamentária e extra-orçamentária.





SISTEMA PATRIMONIAL

Registra os fatos não financeiros ou extra-caixa, tais como: bens móveis, bens imóveis, estoques, operações de crédito, inscrição e baixa da dívida ativa.



SISTEMA ORÇAMENTÁRIO

É representado pelos fatos de natureza orçamentária, tais como: previsão da receita, fixação da despesa, descentralização de créditos e empenho da despesa





SISTEMA ORÇAMENTÁRIO

ATOS DE NATUREZA ORÇAMENTÁRIA:

- ✓ Previsão da Receita
- ✓ Fixação da Despesa
- ✓ Cancelamentos de Créditos
- ✓ Descentralização de Créditos
- ✓ Empenho da Despesa

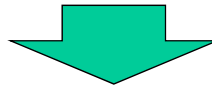

FATOS DE NATUREZA ORÇAMENTÁRIA

- ✓ Arrecadação da Receita
- ✓ Liquidação da Despesa



SISTEMA DE COMPENSAÇÃO

É representado pelos atos praticados pelo administrados que não afetam o Patrimônio de imediato, mas que poderão vir a afetá-lo. Compreende , apenas, as contas como função precípua de controle.





SISTEMA DE COMPENSAÇÃO

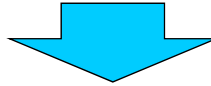

ATOS POTENCIAIS:

- ✓ Contratos
- ✓ Convênios
- ✓ Avais
- ✓ Fianças
- ✓ Comodato de Bens



Estrutura do Compensado

1.9 – ATIVO COMPENSADO

1.9.1 - EXECUCAO ORCAMENTARIA DA RECEITA

1.9.2 - FIXACAO ORCAMENTARIA DA DESPESA

1.9.3 - EXECUCAO DA PROGRAMACAO FINANCEIRA

1.9.5 - EXECUCAO DE RESTOS A PAGAR

1.9.9 - COMPENSACOES ATIVAS DIVERSAS

2.9 – PASSIVO COMPENSADO

2.9.1- PREVISÃO ORCAMENTARIA DA RECEITA

2.9.2 - EXECUCAO ORCAMENTARIA DA DESPESA

2.9.3 - EXECUCAO DA PROGRAMACAO FINANCEIRA

2.9.5 - EXECUCAO DE RESTOS A PAGAR

2.9.9 - COMPENSACOES PASSIVAS DIVERSAS

 SISTEMA ORÇAMENTÁRIO

 SISTEMA DE COMPENSAÇÃO





Exemplo de Registro de Atos Potenciais

Assinatura de Contratos

D – Contratos de Serviços (199720200)

C - Direitos e Obrigações Contratadas (299700000)



Execução da Receita - Previsão

1 - ATIVO ... 1.9 - COMPENSADO ... 1.9.1.1.1- RECEITA A REALIZAR (D) SO	2 – PASSIVO ... 2.9 – COMPENSADO ... 2.9.1.1.1 – PREVISÃO INICIAL (C) DA RECEITA SO
3 - DESPESA	4 - RECEITA
5 - VAR. PATRIMONIAL PASSIVA	6 - VAR. PATRIMONIAL ATIVA





Execução da Receita - Lançamento

1 - ATIVO 1.1 - CIRCULANTE 1.1.2 – CRÉDITOS EM CIRCULAÇÃO RECEITA A RECEBER (D) ... SP 1.9 – COMPENSADO	2 - PASSIVO 2.1 - CIRCULANTE 2.2 - EXIGÍVEL A LONGO PRAZO 2.3 - RES.DE EXERC.FUTUROS 2.4 - PATRIMÔNIO LÍQUIDO 2.9 - COMPENSADO
3 - DESPESA 3.3 - DESPESAS CORRENTES 3.4 - DESPESAS DE CAPITAL	4 - RECEITA 4.1 - RECEITAS CORRENTES
5 - VAR. PATRIMONIAL PASSIVA	6 - VAR. PATRIMONIAL ATIVA Variação Ativa Extra-Orçamentária (C) SP



Execução da Receita - Arrecadação

1 - ATIVO 1.1- CIRCULANTE 1.1.1 – DISPONÍVEL CONTA ÚNICA (D) ... SF 1.9 – COMPENSADO 1.9.1.1.1- RECEITA A REALIZAR (C) 1.9.1.1.4- RECEITA REALIZADA (D) } SO	2 - PASSIVO 2.1 - CIRCULANTE 2.2 - EXIGÍVEL A LONGO PRAZO 2.3 - RES.DE EXERC.FUTUROS 2.4 - PATRIMÔNIO LÍQUIDO 2.9 - COMPENSADO
3 - DESPESA 3.3 - DESPESAS CORRENTES 3.4 - DESPESAS DE CAPITAL	4 - RECEITA 4.1 - RECEITAS CORRENTES → IMPOSTOS (C) SF
5 - VAR. PATRIMONIAL PASSIVA	6 - VAR. PATRIMONIAL ATIVA





Execução da Despesa - Previsão

1 - ATIVO ... 1.9 – COMPENSADO ... 1.9.2.1.1.01.01 – CRÉD.INICIAL (D) (SO)	2 - PASSIVO ... 2.9 – COMPENSADO ... 2.9.2.1.1.00.00 – CRÉD DISPONÍVEL (C) (SO)
3 - DESPESA	4 - RECEITA
5 - VAR. PATRIMONIAL PASSIVA	6 - VAR. PATRIMONIAL ATIVA



Execução da Despesa - Empenho

1 - ATIVO 1.1- CIRCULANTE 1.2 - REALIZ. LONGO PRAZO 1.4 - PERMANENTE 1.9 - COMPENSADO	2 - PASSIVO ... 2.9 – COMPENSADO ... 2.9.2.1.1.00.00 – CRÉD. DISPONÍVEL (D) 2.9.2.1.3.01.00 - CRÉD. EMP. A LIQ. (C) (SO)
3 - DESPESA	4 - RECEITA
5 - VAR. PATRIMONIAL PASSIVA	6 - VAR. PATRIMONIAL ATIVA





TIPO DE UTILIZAÇÃO

0	EVENTO DE GESTOR
1	EVENTO DE SISTEMA
2	EV.COMPLEMENTAR DE EV. DE GESTOR
3	EV.COMPLEMENTAR DE EV. DE SISTEMA
5	ESTORNO DE EVENTO DE GESTOR
6	ESTORNO DE EVENTO DE SISTEMA
7	ESTORNO DE EV. COMPL. DE EV. DE GESTOR
8	ESTORNO DE EV. COMPL. DE EV. DE SISTEMA



CLASSE DOS EVENTOS

10	Previsão de Receitas
20	Dotação de Despesa
30	Movimentação de Crédito
40	Empenho da Despesa
50	Apropriações, Retenções, Liquidações e outros
51	Apropriação de Despesa
52	Retenção de Obrigações
53	Liquidação de Obrigações
54	Registros Diversos
55	Apropriação de Direitos
56	Liquidação de Direitos
58	Registros Diversos
61	Liquidação de Restos a Pagar
70	Transferências Financeiras
80	Receitas





EVENTOS

10
20
30
40
54
58

PREENCHIMENTO DE FORMA INDIVIDUAL

51
53
55
61
70

PARTIDA CONTÁBIL PREDOMINANTEMENTE DE DÉBITO

52
56
80

PARTIDA CONTÁBIL PREDOMINANTEMENTE DE CRÉDITO



1 - ATIVO



D 55.0.xxx

Apropriação de Direitos



C 56.0.xxx

Liquidação de Direitos

2 - PASSIVO



C 52.0.xxx

Retenção de Obrigações



C 53.0.xxx

Liquidação de Obrigações

3 - DESPESA



D 51.0.xxx

Apropriação de Despesa

4 - RECEITA



C 80.0.xxx

Apropriação de Receitas





Obrigado pela Atenção!!!



Secretaria do Tesouro Nacional - STN
Coordenação-Geral de Contabilidade –
CCONT/STN

Email :
genoc.ccont.df.stn@fazenda.gov.br

